

TM 9-4910-700-14&P

TECHNICAL MANUAL

**OPERATOR'S, ORGANIZATIONAL, DIRECT SUPPORT
AND GENERAL SUPPORT MAINTENANCE MANUAL
INCLUDING REPAIR PARTS LIST**

FOR

**TEST SET, TACHOMETER, DWELL
(AUL INSTRUMENTS, INC.)
(NSN 4910-00-788-8549)**

HEADQUARTERS, DEPARTMENT OF THE ARMY

JUNE 1981

WARNING

CAUTION SHOULD BE EXERCISED WHEN WORKING WITH SECONDARY IGNITION SYSTEMS. HIGH VOLTAGE IS PRESENT WHICH CAN CAUSE INJURY DIRECTLY THROUGH ELECTRICAL SHOCK, OR INDIRECTLY THROUGH REFLEX ACTIONS RESULTING IN INJURY. ALSO, WHEN WORKING IN THE ENGINE COMPARTMENT OF AUTOMOBILES AND TRUCKS, CARE SHOULD BE TAKEN TO AVOID ROTATING PARTS SUCH AS FAN BLADES AND BELTS.

Technical Manual }
No. 9-4910-700-14&P }

HEADQUARTERS
DEPARTMENT OF THE ARMY
Washington, DC, 19 June 1981

Operator's, Organizational, Direct Support
and General Support Maintenance Manual
Including Repair Parts List

For

**TEST SET, TACHOMETER, DWELL
(AUL INSTRUMENTS, INC.)
(NSN 4910-00-788-8549)**

REPORTING ERRORS AND RECOMMENDING IMPROVEMENTS

You can help improve this manual. If you find any mistakes or if you know of a way to improve the procedures, please let us know. Mail your letter, DA Form 2028 (Recommended Changes to Publications and Blank Forms), or DA Form 2028-2, located in the back of this manual direct to: Commander, US Army Armament Materiel Readiness Command, ATTN: DRSAR-MAS, Rock Island, IL 61299. A reply will be furnished directly to you.

NOTE

This manual is published for the purpose of identifying an authorized commercial manual for the use of the personnel to whom this equipment is issued.

Manufactured by: Aul Instruments, Inc.
1400 Plaza Avenue
New Hyde Park, NY 11040

Procured under Contract No. DAAA09-78-C-4852

This technical manual is an authentication of the manufacturers' commercial literature and does not conform with the format and content specified in AR 310-3, Military Publications. This technical manual does, however, contain available information that is essential to the operation and maintenance of the equipment.

INSTRUCTIONS FOR REQUISITIONING PARTS

NOT IDENTIFIED BY NSN

When requisitioning parts not identified by National Stock Number, it is mandatory that the following information be furnished the supply officer.

- 1 - Manufacturer's Federal Supply Code Number - 25778
- 2 - Manufacturer's Part Number exactly as listed herein.
- 3 - Nomenclature exactly as listed herein, including dimensions, if necessary.
- 4 - Manufacturer's Model Number -
- 5 - Manufacturer's Serial Number (End Item)
- 6 - Any other information such as Type, Frame Number, and Electrical Characteristics, if applicable.
- 7 - If DD Form 1348 is used, fill in all blocks except 4,5, 6, and Remarks field in accordance with AR 725-50.

Complete Form as Follows:

- (a) In blocks 4, 5, 6, list manufacturer's Federal Supply Code Number - 25778 followed by a colon and manufacturer's Part Number for the repair part.
- (b) Complete Remarks field as follows:
Noun : (nomenclature of repair part)
For: NSN : 4910-00-788-8549
Manufacturer: Aul Instruments, Inc.
1400 Plaza Avenue, New Hyde Park, NY 11040
Model:
Serial: (of end item)

Any other pertinent information such as Frame Number, Type, Dimensions, etc.

OPERATION AND MAINTENANCE MANUAL
FOR THE
TEST SET, TACHOMETER - DWELL
NSN 4910-00-788-8549

Table of Contents

		Paragraph	Page
CHAPTER 1.	INTRODUCTION AND SPECIFICATIONS		
	Introduction	1-1	1-1
	Safety precautions	1-2	1-1
	Description	1-3	1-1
	Specifications	1-4	1-1
CHAPTER 2.	OPERATING INSTRUCTIONS		
	General	2-1	2-1
	Tachometer operation	2-2	2-1
	Dwell meter operation	2-3	2-1
	Points check operation	2-4	2-2
CHAPTER 3.	THEORY OF OPERATION		
	General	3-1	3-1
	Tachometer circuit	3-2	3-1
	Dwell meter	3-3	3-1
	Points resistance meter	3-4	3-1
CHAPTER 4.	MAINTENANCE		
	General	4-1	4-1
	Performance verification	4-2	4-1
	Cleaning and lubrication	4-3	4-3
	Adjustments	4-4	4-3
	Troubleshooting	4-5	4-4
	Repair	4-6	4-4
CHAPTER 5.	PARTS LIST		
	General	5-1	5-1
CHAPTER 6.	CALIBRATION PROCEDURE	6-1	

LIST OF ILLUSTRATIONS

	Title	Page
Figure		
2-1	Operators controls and indicators	2-0
2-2	Tachometer connection	2-2
3-1	Schematic diagram	3-2
4-1	Dwell meter test setup	4-2
4-2	Tachometer test setup	4-2
5-1	Parts location	5-2
6-1	Connection of equipment	6-4
6-2	Set up of equipment	6-4
6-3	Connection of equipment	6-5

LIST OF TABLES

	Title	Page
Table		
1-1	Specifications and data	1-1
2-1	Operators controls and indicators	2-1
4-1	Test equipment	4-1
4-2	Accessories required	4-1
4-3	Tachometer troubleshooting	4-5
4-4	Dwell meter troubleshooting	4-6
5-1	Test set parts list	5-1

CHAPTER 1

INTRODUCTION AND SPECIFICATIONS

1-1. INTRODUCTION. This manual covers test set, tachometer-dwell.

The manual contains instructions for operation and maintenance of the test set.

1-2. SAFETY PRECAUTIONS, The following safety precautions are applicable to the use of the test set.

//WARNING //

CAUTION SHOULD BE EXERCISED WHEN WORKING WITH SECONDARY IGNITION SYSTEMS. HIGH VOLTAGE IS PRESENT WHICH CAN CAUSE INJURY DIRECTLY THROUGH ELECTRICAL SHOCK, OR INDIRECTLY THROUGH REFLEX ACTIONS RESULTING IN INJURY. ALSO, WHEN WORKING IN THE ENGINE COMPARTMENT OF AUTOMOBILES AND TRUCKS, CARE SHOULD BE TAKEN TO AVOID ROTATING PARTS SUCH AS FAN BLADES AND BELTS.

1-3. DESCRIPTION, The test set has two panel meters which simultaneously display the engine r.p.m. and dwell angle. The tachometer operates off of an indirect secondary impulse pickup which can be clipped around any of the spark-plug wires. The dwell meter is connected across the distributor points to ground. It has provisions for measuring dwell angle directly in degrees for 8, 6 and 4 cylinder four cycle engines, Errors in r.p.m. will result when used with 2 cycle engines.

1-4. SPECIFICATIONS. Table 1-1 gives the specifications and pertinent data for the test set.

TABLE 1-1. SPECIFICATIONS AND DATA

FUNCTIONS

Engine RPM

Ranges

0-1000rpm; 0-5000rpm

Accuracy

±3% of full scale readings

Dwell

Ranges (6 and 8 cyl engines)

0-60 degrees

Ranges (4 cyl engines)

0-90 degrees

Ranges (all configurations)

0-100 percent

Accuracy

±3% of full scale readings

Point Voltage

Ranges

0-1 volt

Accuracy

±.03 volts at .2 volts

Display

Two 4 1/2" Meters

Operating Power

Vehicle battery 12-16V

Accessories

Indirect probe for tachometer, leads for battery power, lead for dwell connection
Integral carrying case.

Size

9 1/4 x 10 x 3 1/4

Weight

Approximately 9 LBS

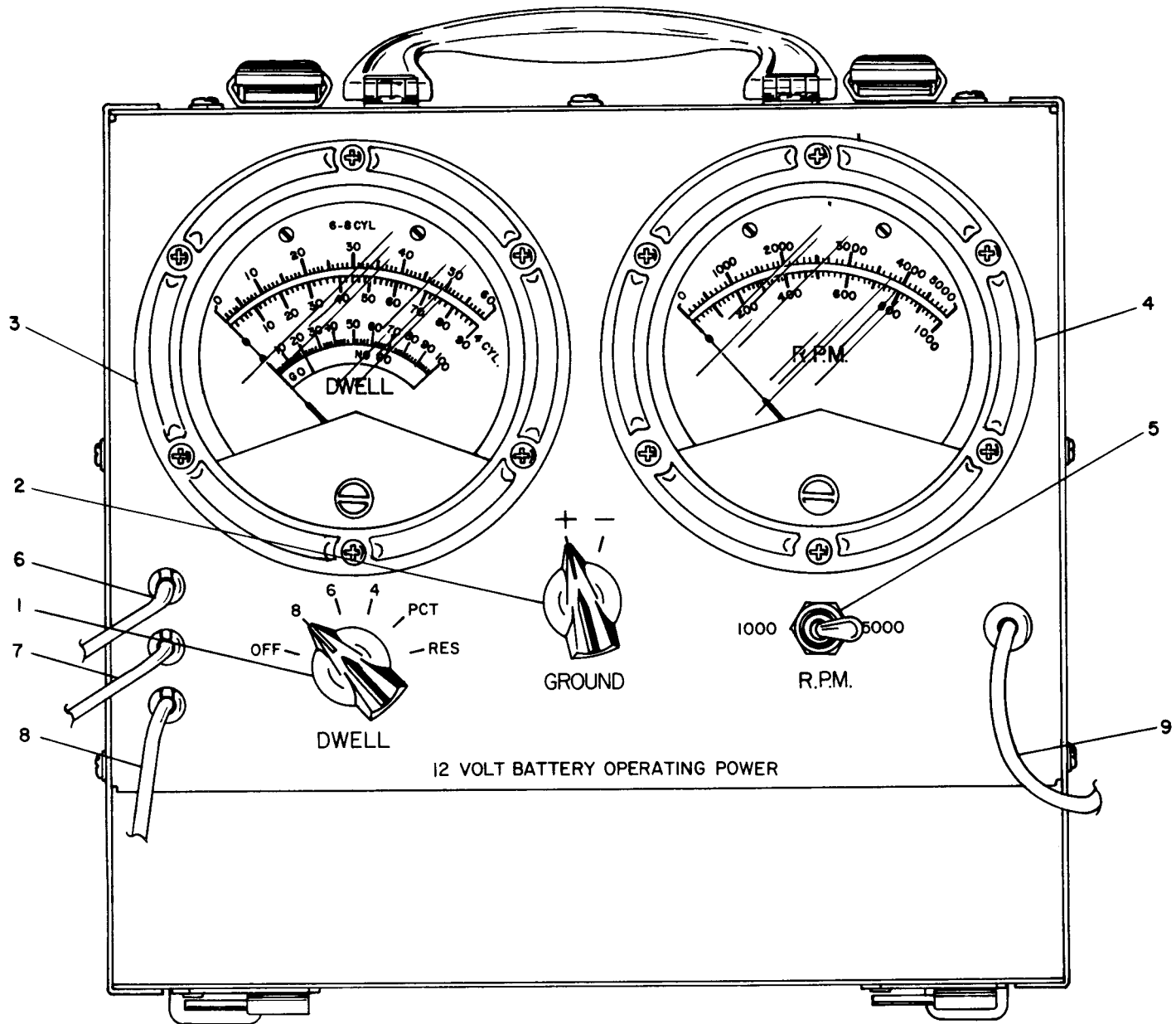

FIG. 2-1. OPERATOR'S CONTROLS AND INDICATORS.

CHAPTER 2

OPERATING INSTRUCTIONS

2-1. GENERAL. This chapter gives all operating procedures for all modes of operation. Figure 2-1 and table 2-1 show all operator's controls and indications.

2-2. TACHOMETER OPERATION. The tachometer lead can be clipped around any of the sparkplug wires. The following procedure should be followed.

- a. Shut engine off if possible,
- b. Note vehicle battery polarity.
- c. Set the dwell switch to the position corresponding to the number of cylinders in the vehicle.
- d. Set the ground switch to the position corresponding to the polarity of the battery ground.
- e. Attach the RED battery lead to the positive terminal of the battery and the BLACK battery lead to the negative terminal of the battery.
- f. Attach the tachometer lead to any convenient secondary wire (see fig. 2-2). Do not connect to the center (spark coil) wire. If a shielded system is used on the vehicle, attach an adapter sparkplug lead.

- g. Make sure that all meter wires are free of belts, fanblades, etc. , and that the meter is resting securely on a solid surface.
- h. Start engine. Read RPM on RPM meter. The RPM switch selects the scale in the meter to be used

2-3. DWELL METER OPERATION. The dwell meter may be used simultaneously with the tachometer, or without the tachometer.

- a. Note vehicle battery polarity and number of cylinders.
- b. Set ground switch to the position corresponding to the polarity of the battery ground.
- c. Set dwell switch to the dwell position corresponding to the number of cylinders of the vehicle.
- d. Locate the spark coil terminal which is connected to the distributor.
- e. Start engine. The dwell will be read on the meter scale corresponding to the number of cylinders as selected on the dwell switch.

TABLE 2-1. OPERATOR'S CONTROLS AND INDICATORS

<u>NAME</u>	<u>DESCRIPTION</u>	<u>INDEX NO</u>
DWELL SWITCH	Selects 8,6,4 cyl,percent,and points resistance.	1
GROUND SWITCH	Selects for positive or negative grounded systems.	2
DWELL METER	Displays dwell and point resistance.	3
RPM meter	Displays engine RPM.	4
RPM SWITCH	Selects 1000 or 5000 RPM.	5
DWELL LEAD	Connect to distributor primary lead	6
BAT + LEAD	Connected to positive battery terminal	7
BAT - LEAD	Connected to negative battery terminal.	8
TACH LEAD	Clips around any sparkplug wire.	9

2-4. POINTS CHECK OPERATION. The test set has built-in provision for testing the condition of distributor breaker points.

- a. Follow steps a through d of paragraph 2-3.
- e. Note meter reading with engine off but ignition switch on. If meter reads upscale, it is necessary to advance engine by cranking until meter does not deflect.

/NOTE/

If the engine is warm, it may be necessary to disconnect the spark coil secondary wire to avoid starting engine while cranking.

- f. Set the dwell switch to the RES position.
- g. Read the points condition on the GO-NO-GO scale of the meter. A NO-GO condition is equivalent to .2 volts of points voltage drop or more.

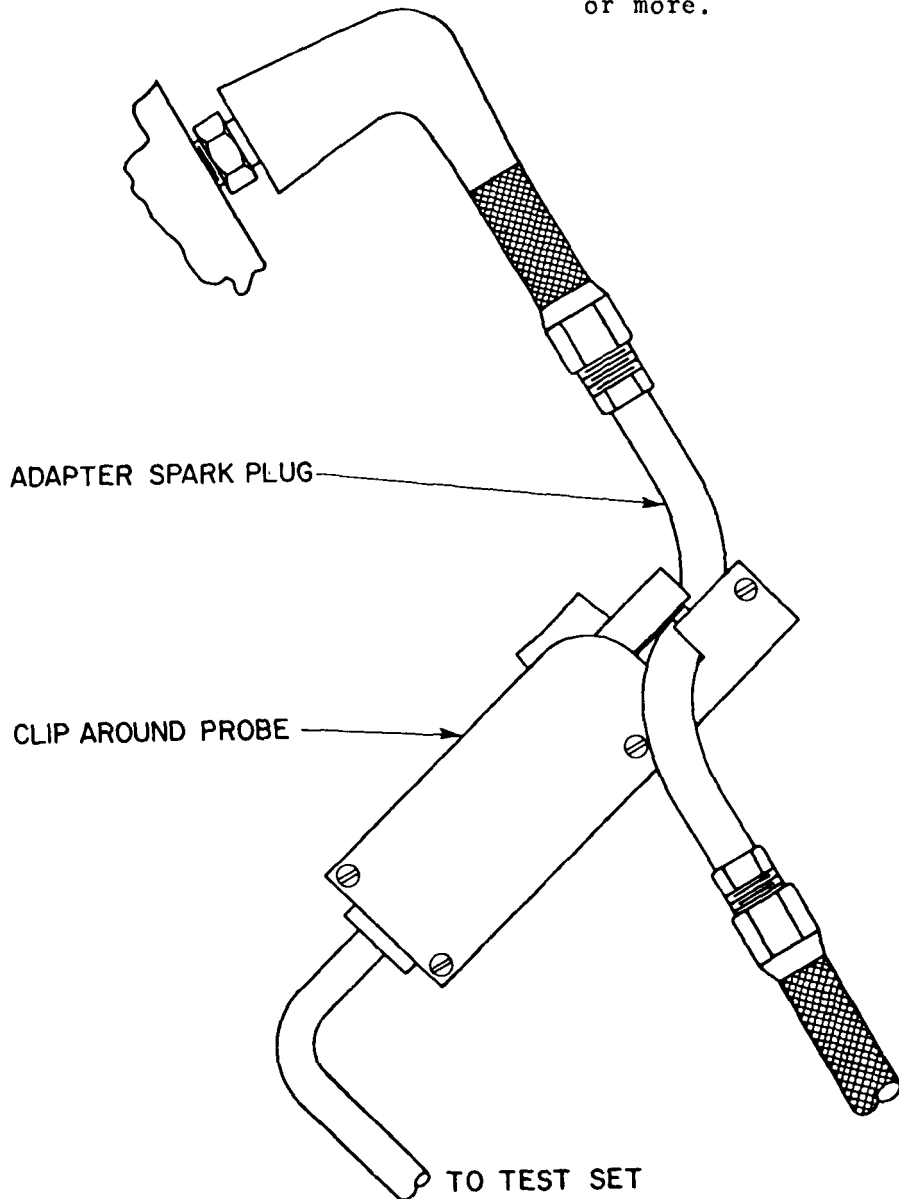

FIG 2-2. TACHOMETER CONNECTION

CHAPTER 3

THEORY OF OPERATION

3-1. GENERAL. This chapter describes the theory of operation of the test set. Refer to figure 3-1, schematic diagram.

3-2. TACHOMETER CIRCUIT. The tachometer circuit is powered by the vehicle battery power (12 volts). The power is applied through CR1, the polarity protection diode, to R1 and CR2 which provide the base drive for Q1, the voltage regulator. The signal input is applied to the base of Q2, a switch, which produces a positive pulse at its collector. This positive pulse is then applied to the base of Q3 through C3 making the collector of Q3 go low, therefore starting the fixed timing cycle which is made up of R6, C4, Q4, and Q5. The fixed width pulse at the collector of Q5 is inverted by Q6 and applied to the base of Q7 which is in series with M1 and S3. Switch S3 allows current to flow through M1, the RPM meter, for the duration of the fixed length pulse. Since the number of pulses is proportional to the engine RPM, the meter displays engine RPM. R16 provides an internal calibration adjustment for the 1000 RPM range and R14 for the 5000 RPM range.

3-3. DWELL METER. The dwell meter circuitry measures the length of time that the points are closed compared to the total time for firing one cylinder of the engine. This is accomplished by attaching the DWELL lead to the primary ignition wire connecting the spark coil primary to the distributor breaker points. When the points are closed, there is approximately zero volts between ground and the DWELL lead. When the points are open, the voltage across the points is near the battery voltage. The circuit will measure dwell for both negative and positive grounded systems.

a. Negative Grounded Systems. When used with negative grounded systems, the ground switch is in the "-" position. The distributor points are thus connected between the base of Q9 and ground through R20. When the points are open, Q9 is on. When the points are closed, Q9 is off. Q9 controls Q10. When Q9 is off, a constant current flows

through R24, established by the fixed zener voltage on the base of Q10 and resistor R25. When the points are open, Q9 is on and Q10 is off. The voltage drop across R24 is thus a constant value when the points are closed, and zero when the points are open. The average drop relative to the peak voltage is the percentage dwell angle. When the meter is calibrated in degrees for an engine of a given number of cylinders, the meter will read directly in degrees of dwell. Switch S2 selects either R28 and R29 or R26 and R27, in series with the meter. R28 is calibrated so that full scale on the meter corresponds to either 100% of percentage dwell, 60 degrees of dwell for 6 cylinder engines, or 90 degrees of dwell for 4 cylinder engines. R26 is calibrated to that 100% of dwell reads 45° on the 60° scale, for 8 cylinder engines.

b. Positive Grounded Systems. For positive grounded system, the DWELL lead is connected to the base of Q8 through R18. When the points are closed the voltage at the collector Q8 is approximately zero, with respect to the battery + lead. Q8 is therefore on and Q9 is off. When the points are open (negative with respect to battery +), Q8 is off, and Q9 is on. The rest of the dwell circuitry functions identically to the negative grounded system.

3-4. POINTS RESISTANCE METER. The test set measures the voltage drop across closed points for both positive and negative grounded systems. In both cases, the DWELL meter is connected in series with a fixed resistor (R1) to form a voltmeter with a full scale sensitivity of one volt. The GO-NO-GO mark is calibrated at 0.2 volts. For negative grounded systems, the meter is connected from the DWELL lead to BATTERY by S1, the ground switch. For positive grounded systems, the meter is connected from the DWELL lead to BATTERY + by S1.

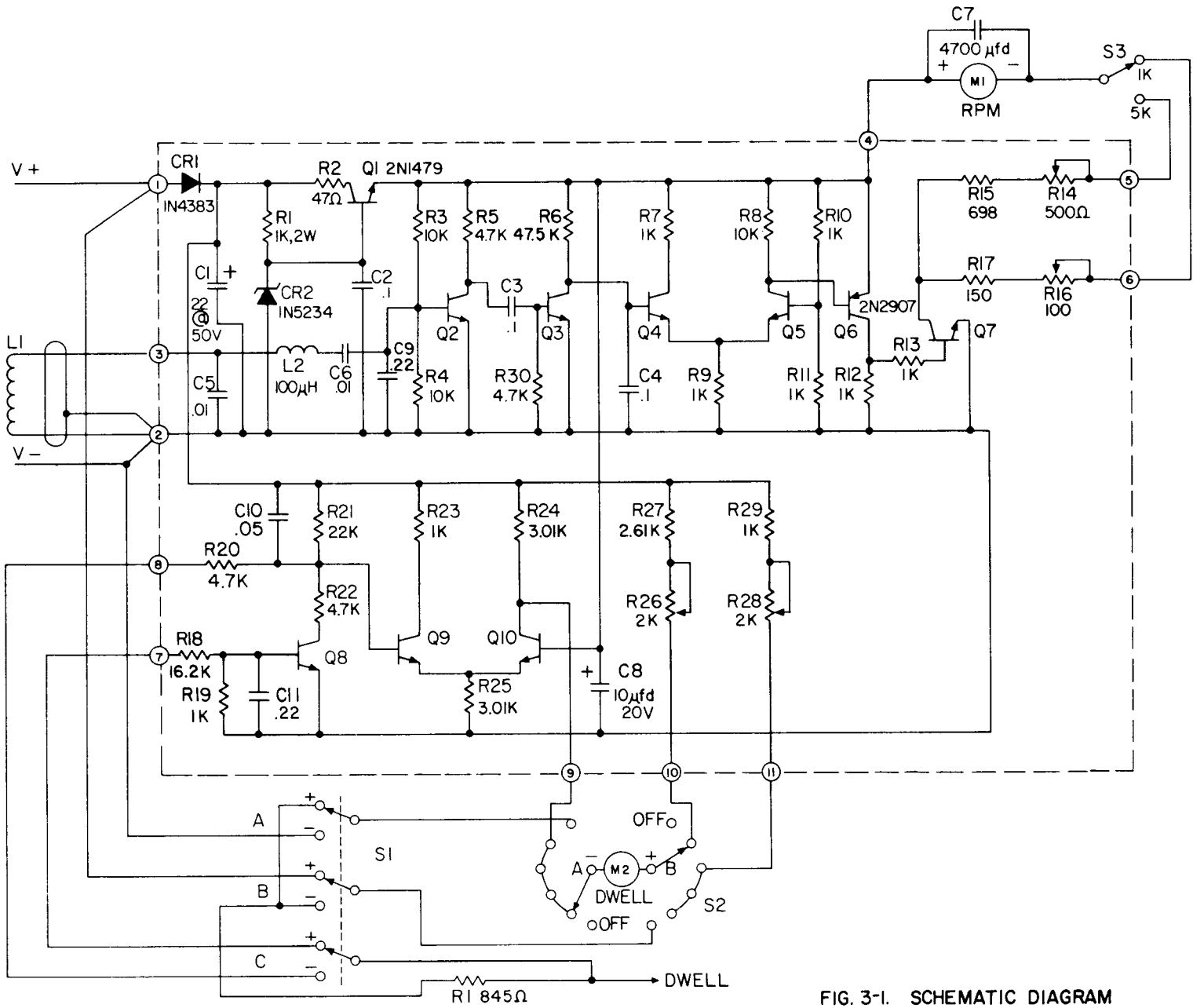

FIG. 3-1. SCHEMATIC DIAGRAM

CHAPTER 4
 MAINTENANCE

4-1. GENERAL. This chapter covers all phases of maintenance of the test set. Performance verification will determine if a given test set is performing within specifications. The cleaning and lubrication section provides instructions for cleaning the test set. No lubrication is required. The adjustments instructions are for calibrating the test set to remove minor drifts due to aging or replacements of components. The repair section contains instructions for parts and component replacements.

4-2. PERFORMANCE VERIFICATION. The performance verification test is used to determine if a given test set is operating within specifications. Slight variations from the tolerances given indicate probable need for recalibration, Gross variations indicate the need for troubleshooting and repair.

- a. Required Test Equipment. Table test equipment required for calibration.

TABLE 4-1. TEST EQUIPMENT

<u>NAME</u>	<u>Mfr./MODEL</u>	<u>NSN</u>
Pulse Generator	Hewlett-Packard 214A	4931-00-490-0776
Electronic Counter	Hewlett-Packard 52-45L	
Power Supply	General Purpose 20 Volts	

- b. Accessory Equipment Required. Table 4-2 lists the accessories required for calibration.

TABLE 4-2. ACCESSORIES REQUIRED

<u>NAME</u>	<u>DESCRIPTION</u>
Cable, Test	BNC-type connectors on one end and alligator clips for connecting test equipment to unit under test.(2 req.)
c. <u>Dwell Meter Test</u> ,	
1. Set up equipment as in figure 4-1. Set to test set on 8 lobe position.	to an engine RPM of 1500 and a dwell of 22.5°. The meter under best should read between 20.7° and 24.3 .
2. Set pulse generator for a 20 volt pulse at 200Hz repetition rate and 2.5 millisecond width.	4. Switch the unit under test to the 4 lobe position. The meter should now read between 42.3° and 47.7°.
3. Adjust repetition rate to exactly 200Hz and 2.5 millisecond width using electronic counter. This corresponds	5. Switch the unit under test to the 6 lobe position. The meter under test should read between 28.2° and 31.8°.

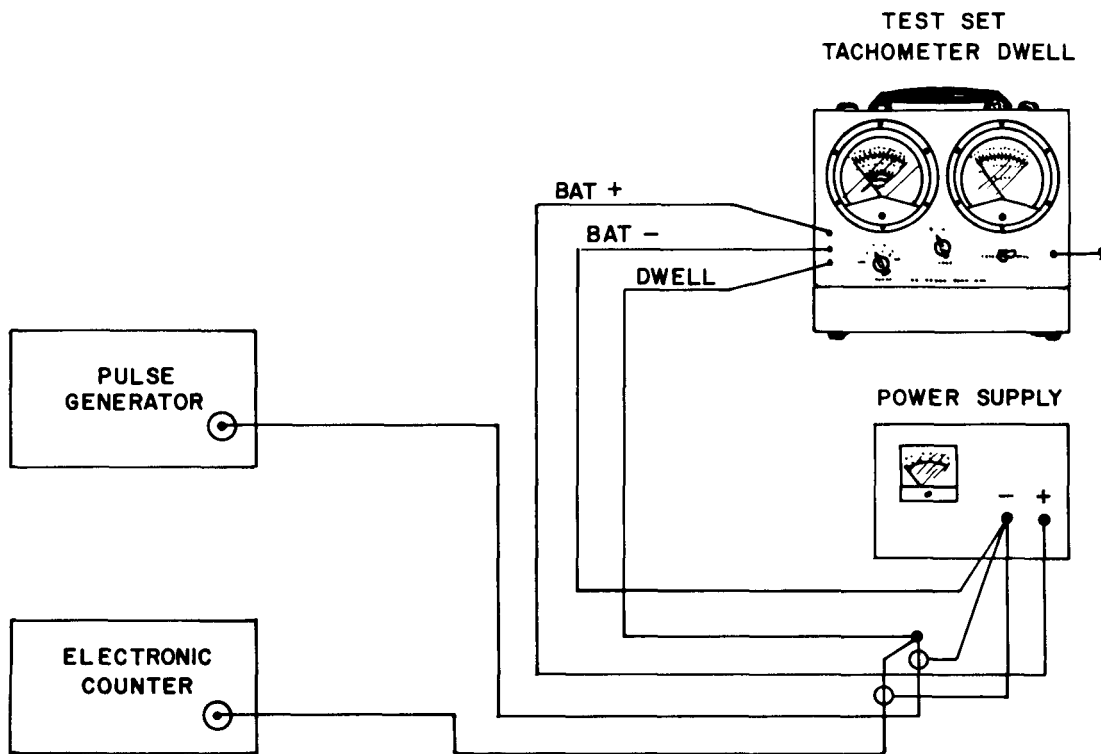

FIG. 4-1. DWELL METER TEST SETUP

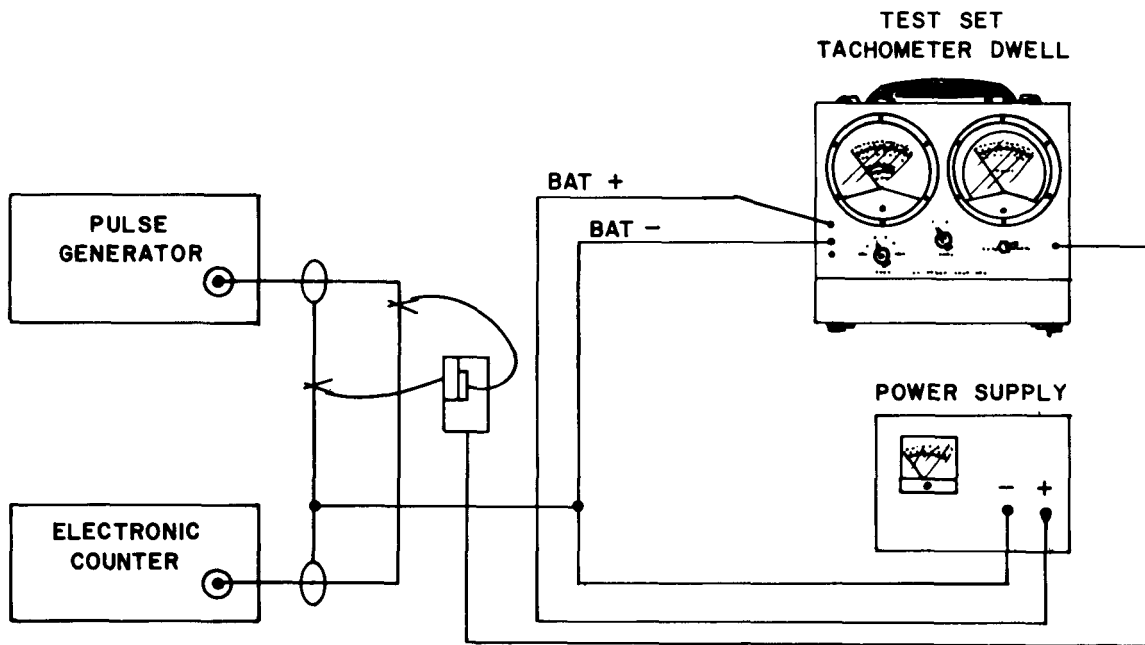

FIG. 4-2. TACHOMETER TEST SETUP

d. Tachometer Test.

1. Connect equipment per figure 4-2. Set unit under test to 1000 RPM.
2. Set pulse generator for a repetition rate of 16.66pps (1000ppm), a width of 10 microseconds, and 20 volt amplitude. Verify the repetition rate using the electronic counter.
3. Unit under test should read between 970 and 1030rpm.
4. Reset pulse generator for 83.33pps (5000ppm).
5. Unit under test should read between 4850 and 5150rpm.
6. Reset pulse generator for 41.666pps (2500rpm). Meter should read between 2350 and 2650rpm.

4-3. CLEANING AND LUBRICATION. Cleaning procedures are limited to the following. No lubrication of the test set is required. Oils, greases, and other lubricants are not to be introduced into the interior of the test set.

- a. Exterior Cleaning. The exterior of the test set can be cleaned with a mild solvent and a soft rag. Do not use abrasive cleaners,
- b. Interior Cleaning. Interior cleaning should only be performed when the test set has undergone some contamination, or after extended usage.
 1. Remove the test set panel assembly from the case (see fig 5-1).
 2. Carefully clean the circuit board, exterior of the switches, etc. , using a cotton swab and a mild solvent. Be sure that any residue from the swab is removed.
 3. Re-assemble the test set.

4-4. ADJUSTMENTS. Adjustments are used to calibrate the test set to correct for minor drifts due to component aging or replacement. It should not be necessary to make adjustments at less than six month intervals, unless components have been replaced.

a. Dwell Meter Calibration.

1. Set the ground switch to - and connect the dwell lead to the -12V lead.
2. Set the dwell switch on the unit under test to the 4 lobe position and adjust R26 for a full scale (90°) indication of the DWELL meter.
3. Set the DWELL switch on the unit under test to the 8 lobe position and set R28 for a 45 indication on the DWELL meter.
4. Set up equipment as in figure 4-1. Leave unit under test set on 8 lobe position.
5. Set pulse generator for a 20 volt pulse at 100Hz repetition rate and 5 millisecond width,
6. Adjust repetition rate to exactly 100Hz and 5 millisecond width using electronic counter. This corresponds to an engine RPM of 1500 and a dwell of 22.5°. The meter under test should read between 20.7° and 24.3°.
7. Switch the unit under test to the 4 lobe position. The meter should now read between 42.3° and 47,7°.

b. Tachometer Calibration.

1. Connect equipment per figure 4-2. Set unit under test to 1000 RPM.
2. Remove the loop across the pulse generator and adjust its output for a 10 microsecond pulse width at an amplitude of 20 volts.

3. Adjust the repetition rate using the electronic counter to 8.333PPS (1000RPM). Reconnect the loop to the output of the generator.
4. Adjust R16 for an exact 1000RPM indication on the meter under test.
5. Repeat step 2 and adjust the repetition rate to 41.66PPS (5000RPM).
6. Connect the loop and adjust R14 on the test unit for an exact indication of 5000RPM.
7. Repeat step 2 and adjust the repetition rate for 20.833PPS (2500RPM). Reconnect the loop. The meter should read between 2350 and 2650 RPM.

4-5. TROUBLESHOOTING. Troubleshooting may be best accomplished by use of the following procedure.

- a. Tachometer Troubleshooting. Table 4-3 lists some symptoms and probable defects for the tachometer. Locate the symptoms and follow the indicated fault isolation procedures.
- b. Dwell Meter and Points Resistance Troubleshooting. Table 4-4 lists symptoms and probable defects for the dwell meter and points resistance circuit.

4-6. REPAIR, Repair procedures for the test set are limited to replacement of defective components.

- a. Replacement of Board Mounted Electronic Components. When replacing parts on circuit boards, it is recommended that a soldering iron of 40 watts or less be used. After removing the component, clear the solder out of the holes in the circuit board before re-inserting. Remove flux residue with Freon TMC or Trichloroethane after re-soldering.
- b. Replacement of Chassis Mounted Components. Chassis mounted components should be replaced using proper mechanical assembly practices. Be sure to retain all mounting hardware when replacing parts. Refer to chapter 5 for parts listing.

TABLE 4-3. TACHOMETER TROUBLESHOOTING

<u>SYMPTOM</u>	<u>POSSIBLE CAUSE</u>	<u>FAULT ISOLATION PROCEDURE</u>
No meter deflection	Defective Pickup	Using ohmmeter, perform continuity tests between tachometer pickup leads at their connection to the circuit board (panel assembly interior). A reading below 2 ohms is normal for the resistance of the pickup. A reading above 2 ohms indicates that the pickup, or the leads to the pickup may be open.
	Shorted CR2	Check with Ohmmeter
	Q1 Open	Check with Ohmmeter
	Q2 Shorted	Check with Ohmmeter
	Q3 Open	Check with Ohmmeter
	Q4 Shorted	Check with Ohmmeter
	Q5 Open	Check with Ohmmeter
	Q6 Open	Check with Ohmmeter
	Q7 Open	Check with Ohmmeter
	M1	Check across meter terminals with ohmmeter on RX10 range. Meter should deflect (left or right, depending on ohmmeter polarity). Do not leave ohmmeter connected to meter for an extended period of time.
Meter inaccurate	CR2 Open	Check for 6.5 volts $\pm 10\%$ across CR2. Check for 5.5 volts from PIN4 to ground.

TABLE 4-4. DWELL METER TROUBLESHOOTING

<u>SYMPTOM</u>	<u>POSSIBLE CAUSE</u>	<u>FAULT ISOLATION PROCEDURE</u>
No meter deflection (negative ground)	Q10 Open	Check with Ohmmeter
	Q9 Shorted	Check with Ohmmeter
No meter deflection (positive ground)	Q8 Open	Check with Ohmmeter
Inaccurate readings	CR2 defective	Check for 6.5V $\pm 10\%$ across CR2
	Leads defective	Check for 5.5 from PIN4 to ground
	Meter M2 defective	Check across meter terminals with ohmmeter on RX10 range. Meter should deflect (left or right, depending on ohmmeter polarity). Do not leave ohmmeter connected to meter for an extended period of time.
Meter deflects to full scale	Q9 Open	Check with Ohmmeter
	Q8 Shorted	Check with Ohmmeter
Meter deflects beyond full scale	Q10 Shorted	Check with Ohmmeter
Points resistance does not indicate	R1 Open	Check using Ohmmeter
	S1 defective	Check using Ohmmeter

CHAPTER 5
PARTS LIST

5-1. GENERAL.FIGURE 5-1 SHOWN ALL REPLACEABLE PARTS FOR THE TEST SET. TABLE 5-1 LISTS THE PARTS SHOWING MANUFACTURER, INDEX NUMBER, REFERENCE DESIGNATION (FOR ELECTRONIC PARTS) AND MANUFACTURER'S PART NUMBER. TABLE 5-2 LISTS THE MANUFACTURER'S NAME AND ADDRESS REFERRED TO THE FEDERAL SUPPLY CODE FOR MANUFACTURERS.

TABLE 5-1. TEST SET PARTS LIST

REF. DES.	PART NAME & DESCRIPTION	FSCM	MFG. PART NO.	AUL PART NO.
A1	CIRCUIT BOARD ASSEMBLY	25778	101425	101425
A1C1	CAPACITOR FDX TANT 22UF 50V 20%	56289	CSR13G226M	300692
A1C2	CAPACITOR FXD CER. .1	30039	CD104Z500	300613
A1C3	CAPACITOR FXD CER. .1	30039	CD104Z500	300613
A1C4	CAPACITRO FXD FILM .1	30039	AMG104K251	300607
A1C5	CAPACITOR FXD CER. .01	30039	CD103Z500	300654
A1C6	CAPACITOR FXD CER. .01	30039	CD103Z500	300654
A1C7	CAPACITOR FDX ELEC. 4700UFD 6.3V-10+50%	30039	TDA4700M6R3T	300732
A1C8	CAPACITOR FDX TANT 10UF 20V 10%	56289	CSR13E106KL	300298
A1C9	CAPACITOR FXD FILM .22/100V	30039	EM2200-1A	300041
A1C10	CAPACITOR FXD CER .05/100V	56289	T.G.-S50	300248
A1C11	CAPACITOR FXD FILM .22/100V	30039	EM2200-1A	30041
A1L2	COIL FXD 100UHY 10%	43543	MS-90538-12	351230
A1CR1	DIODE	81349	1N4383	357167
A1CR2	DIODE ZENER	81349	1N5234	357144
A1Q1	TRANSISTOR,NPN	81349	2N1479	357396
A1Q2	TRANSISTOR,NPN	81349	2N2222	357169
A1Q3	TRANSISTOR,NPN	81349	2N2222	357169
A1Q4	TRANSISTOR,NPN	81349	2N2222	357169
A1Q4	TRANSISTOR,NPN	81349	2N2222	357169
A1Q5	TRANSISTOR,NPN	81349	2N2222	357169
A1Q6	TRANSISTOR,PNP	81349	2N2907	357170
A1Q7	TRANSISTOR,NPN	81349	2N2222	357169
A1Q8	TRANSISTOR,NPN	81349	2N2222	357169

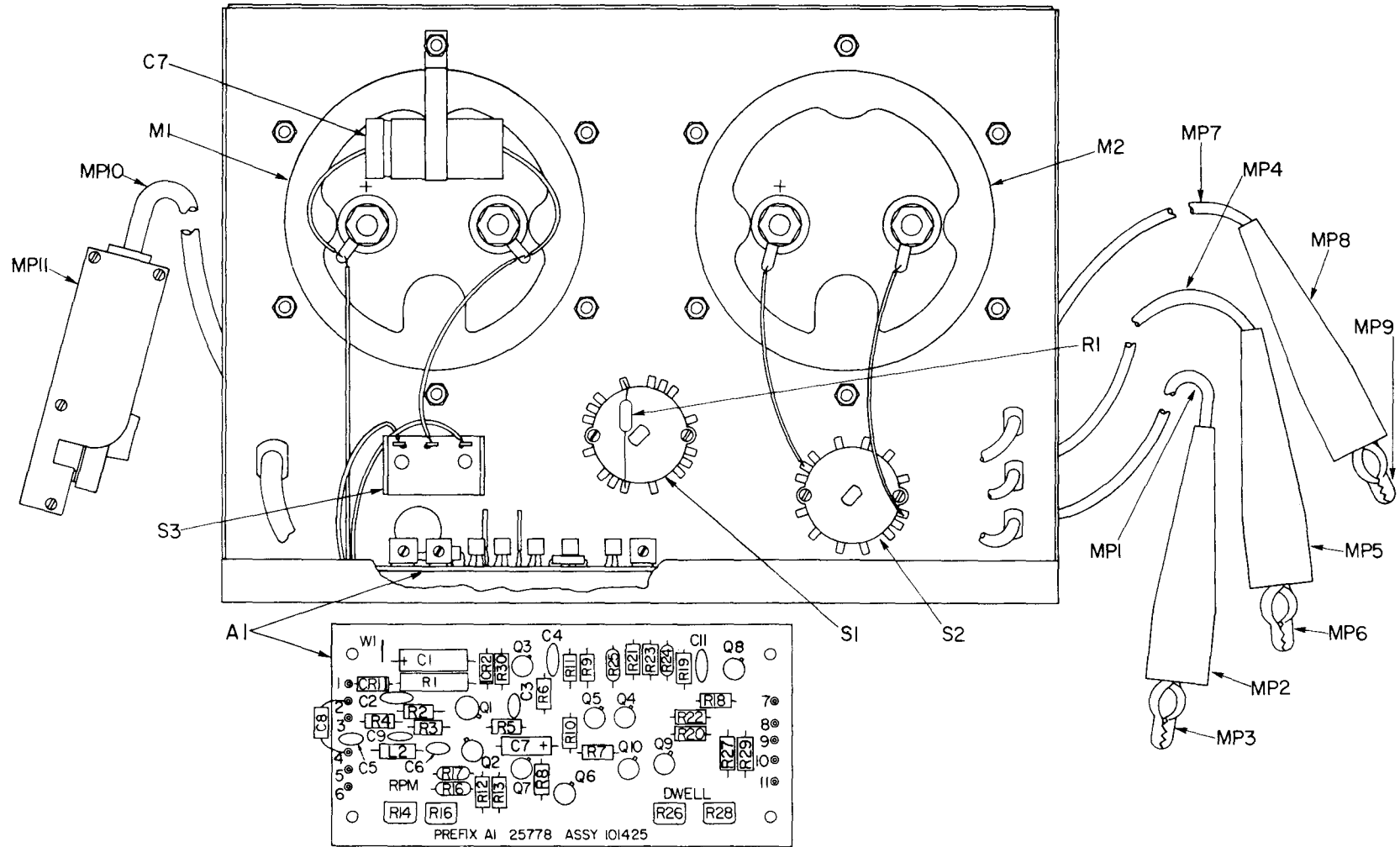

FIG. 5-1. PARTS LOCATION

TABLE 5-1 TEST SET PARTS LIST (CONT.)

REF DES.	PART NAME & DESCRIPTION	FSCM	MFG. PART NO.	AUL PART NO.
A1Q9	TRANSISTOR,NPN	81349	2N2222	357169
A1Q10	TRANSISTOR,NPN	81349	2N2222	357169
A1R1	RESISTOR COMP, 1K 2W 5%	81349	RCR24GF102JS	321739
A1R2	RESISTOR COMP, 47 1/4W 10%	81349	RC07GF470K	320502
A1R3	RESISTOR COMP, 10K 1/4W 10%	81349	RC07GF103K	320490
A1R4	RESISTOR COMP, 10K 1/4W 10%	81349	RC07GF103K	320490
A1R5	RESISTOR COMP, 4.7K 1/4W 10%	81349	RC07GF472K	320805
A1R6	RESISTOR FXD FILM 47.5K 1%	81349	RN55D4752F	321110
A1R7	RESISTOR COMP, 1K 1/4W 10%	81349	RC07GF102K	320222
A1R8	RESISTOR COMP, 10K 1/4W 10%	81349	RC07GF103K	320490
A1R9	RESISTOR COMP, 1K 1/4W 10%	81349	RC07GF102K	320222
A1R10	RESISTOR COMP, 1K 1/4W 10%	81349	RC07GF102K	320222
A1R11	RESISTOR COMP, 1K 1/4W 10%	81349	RC07GF102K	320222
A1R12	RESISTOR COMP, 1K 1/4W 10%	81349	RC07GF102K	320222
A1R13	RESISTOR COMP, 1K 1/4W 10%	81349	RC07GF102K	320222
A1R14	RESISTOR VAR CERMET 500	80294	3386H-1-501	320903
A1R15	RESISTOR FXD FILM 698 1%	81349	RN55D6980F	321760
A1R16	RESISTOR VAR CERMET 100	80294	3386-H-1-101	321320
A1R17	REISTOR FXD FILM 150 1%	81349	RN55D151F	321095
A1R18	RESISTOR FXD FILM 16.2K 1%	81349	RN55D1622F	321198
A1R19	RESISTOR COMP. 1K 1/4W 10%	81349	RC07GF102K	320222
A1R20	RESISTOR, COMP, 4.7K 1/4W 10%	81349	RC07GF472K	320805
A1R21	RESISTOR COMP. 22K 1/4W 10%	81349	RC07GF223K	320500
A1R22	RESISTOR COMP. 4.7K 1/4W 10%	81349	RC07GF472K	320805
A1R23	RESISTOR COMP, 1K 1/4W 10%	81349	RC07GF102K	320222
A1R24	RESISTOR FXD FILM 3.01K 1%	81349	RN55D3011F	321087
A1R25	RESISTOR FXD FILM 3.01K 1%	81349	RN55D3011F	321087
A1R26	RESISTOR VAR CERMET 2K	81349	3386H-1-202K	320907
A1R27	RESISTOR FXD FILM 2.61K 1%	81349	RN55D2611F	321761

TABLE 5-1 TEST SET PARTS LIST (CONT.)

REF. DES.	PART NAME AND DESCRIPTION	FSCM	MFG. PART NO.	AUL PART NO
A1R28	RESISTOR VAR CERMET 2K	80294	3386H-1-202K	320907
A1R29	RESISTOR FXD FILM 1K 1%	81349	RN55D1001F	321107
A1R30	RESISTOR COMP, 4.7K 1/4W 10%	81349	RC07GF472K	320805
M1	METER, RPM	25778	361301	361301
M2	METER, DWELL	25778	3610300	361300
R1	RESISTOR FILM 843/ Ω 1%	81349	RN60D8450F	321762
S1	SWITCH-GROUND	25778	359174 T208 TYPE 212	359174
S2	SWITCH, DWELL	25778	359175	359175
S3	SWITCH, RPM	25778	359176	359176
CP1	CABLE CLAMP, TACH	28520	6P-4	344156
CP2	CABLE CLAMP, BATT & DWELL	28520	2M-4	344368
MP1	LEAD BATT-	25778	202710	202710
MP2	BOOT, BATT- (BLACK)	76545	#26 (BLK)	354136
MP3	CLIP, BATT-	76545	#25	354135
MP4	LEAD, BATT+	25778	202711	202711
MP5	BOOT, BATT+ (RED)	76545	#26 (RED)	354136
MP6	CLIP, BATT+	76545	#25	354135
MP7	LEAD, DWELL	25778	202712	202712
MP8	BOOT, DWELL (RED)	76545	#29 (RED)	368147
MP9	CLIP, DWELL	76545	#27	354094
MP10	LEAD, TACH	25778	202713	202713
MP11	PROBE, CLIP AROUND	25778	101935	101935

CHAPTER 6

CALIBRATION PROCEDURE

TEST SET, TACHOMETER-DWELL

NSN 4910-00-788-8549

1. SCOPE. This procedure is for calibration of Test Set, Tachometer-Dwell, as manufactured by Aul Instruments, Inc. under contract DAAA09-78-C-4852.
2. REQUIRED TEST EQUIPMENT. Table 1 lists test equipment required for calibration.

TABLE 1. TEST EQUIPMENT

<u>NAME</u>	<u>MFR./MODEL</u>	<u>NSN</u>
Pulse Generator	Hewlett-Packard 214A	4931-00-490-0776
Electronic Counter	Hewlett-Packard 52-45L	
Power Supply	General Purpose 20 Volts	

3. ACCESSORY EQUIPMENT REQUIRED. Table 2 lists the accessories required for calibration.

TABLE 2. ACCESSORY EQUIPMENT

<u>NAME</u>	<u>DESCRIPTION</u>
Cable, Test	BNC-type connectors on each end for connecting test equipment. (2 required)
Cable, Accessory	BNC-to clip leads for connecting pulse generator to unit under test. (1 required)
Tee, BNC	BNC Tee to connect test equipment to unit under test. (1 required)

4. CALIBRATION PROCEDURE.

a. DWELL METER CALIBRATION

- 1) Connect equipment per figure 6-1.
- 2) Adjust power supply for a 20 volt signal.
- 3) Set the dwell switch on the unit under test to the 4 lobe position and adjust R15 of a full scale (90°) indication on the DWELL meter.
- 4) Set the DWELL switch on the unit under test to the 8 lobe position and set R14 for a 45° indication on the DWELL meter.
- 5) Set up equipment as in figure 6-2. Leave unit under test set on 8 lobe position.
- 6) Set pulse generator for a 20 volt pulse at 200 Hz repetition rate and 2.5 millisecond width.
- 7) Adjust repetition rate to exactly 100 Hz and 5 millisecond width using electronic counter. This corresponds to an engine RPM of 1500 and a dwell of 22.5°. The meter under test should read between 20.7° and 24.3°.
- 8) Switch the unit under test to the 4 lobe position. The meter should now read between 42.3° and 47.7°.

b. TACHOMETER CALIBRATION

- 1) Connect equipment per figure 6-3. Set unit under test to 1000 RPM.

b. TACHOMETER CALIBRATION (continued)

- 2) Set pulse generator for a repetition rate of 8.33 pps (500 ppm), a width of 1 millisecond, and 20 volt amplitude. Verify the repetition rate using the electronic counter.
- 3) Adjust R4 for an exact 1000 rpm indication on the meter under test.
- 4) Reset pulse generator for 41.66 pps (2500 ppm).
- 5) Adjust R9 on unit under test for an exact indication of 5000 rpm.
- 6) Reset pulse generator for 20.83 pps (1250 ppm). Meter should read between 2350 and 2650 rpm.

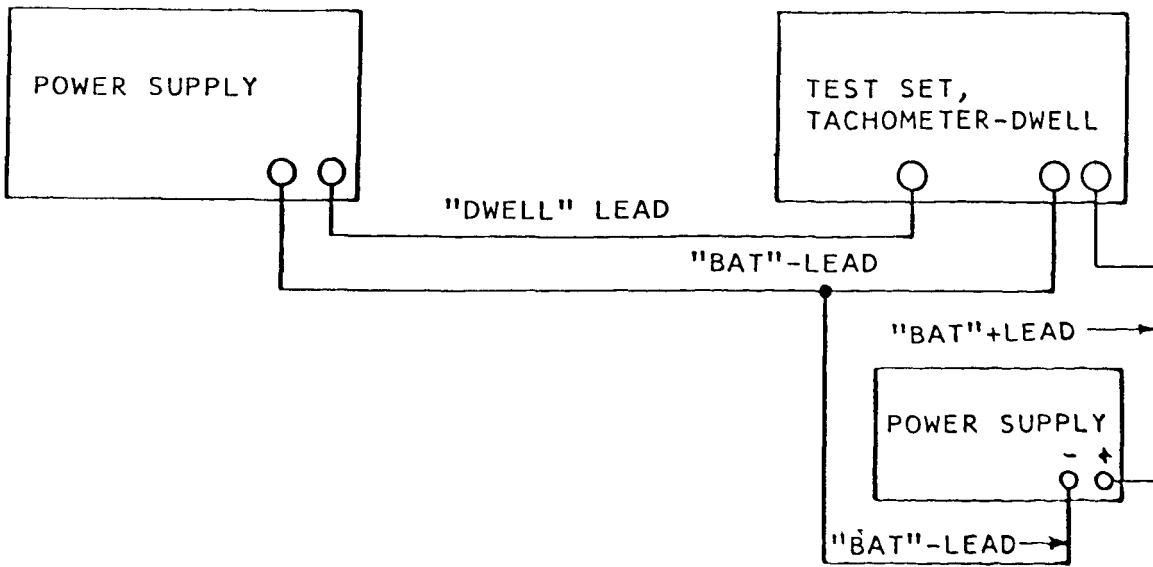

FIGURE. 6-1

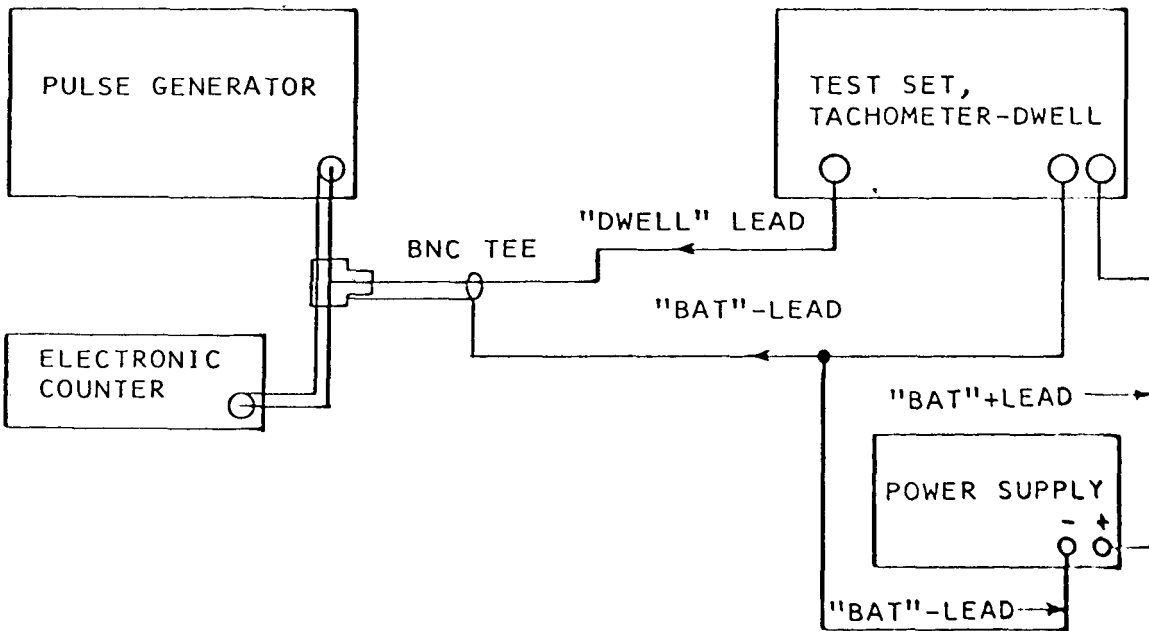

FIGURE. 6-2

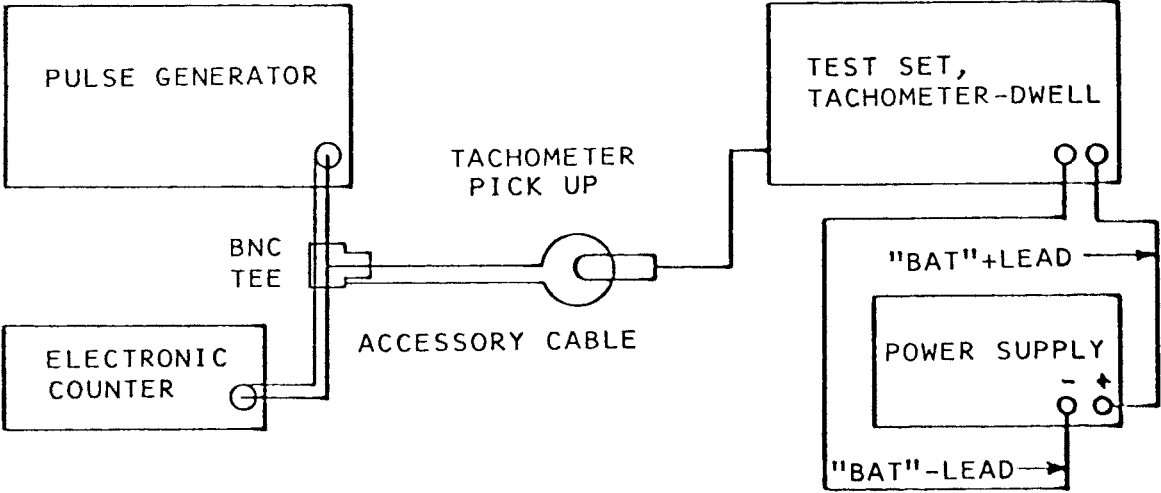

FIGURE. 6-3

By Order of the Secretary of the Army:

Official:

E. C. MEYER
General, United States Army
Chief of Staff

J. C. PENNINGTON
Major General, United States Army
The Adjutant General

Distribution:

To be distributed in accordance with Special List.

RECOMMENDED CHANGES TO EQUIPMENT TECHNICAL PUBLICATIONS



THEN... JOT DOWN THE DOPE ABOUT IT ON THIS FORM, CAREFULLY TEAR IT OUT, FOLD IT AND DROP IT IN THE MAIL!

SOMETHING WRONG WITH THIS PUBLICATION?

FROM: (PRINT YOUR UNIT'S COMPLETE ADDRESS)

Your mailing address

DATE SENT

Date you mailed in form

PUBLICATION NUMBER

TM 9-4910-700-14&P

PUBLICATION DATE

19 June 1981

PUBLICATION TITLE

Test Set, Tachometer, Dwell

BE EXACT... PIN-POINT WHERE IT IS

PAGE NO.

10

PARA-GRAPH

5

FIGURE NO.

TABLE NO.

IN THIS SPACE TELL WHAT IS WRONG AND WHAT SHOULD BE DONE ABOUT IT:

Change Model Number to 64982.

SAMPLE

PRINTED NAME, GRADE OR TITLE, AND TELEPHONE NUMBER

JOHN SMITH SP/4 XXX-XXXX

SIGN HERE:

John Smith

DA FORM 2028-2
1 JUL 79

PREVIOUS EDITIONS ARE OBSOLETE.

P.S.--IF YOUR OUTFIT WANTS TO KNOW ABOUT YOUR RECOMMENDATION MAKE A CARBON COPY OF THIS AND GIVE IT TO YOUR HEADQUARTERS.

FILL IN YOUR
UNIT'S ADDRESS

FOLD BACK

TEAR ALONG PERFORATED LINE

DEPARTMENT OF THE ARMY

OFFICIAL BUSINESS
PENALTY FOR PRIVATE USE \$300

POSTAGE AND FEES PAID
DEPARTMENT OF THE ARMY
DOD 314



Commander
US Army Armament Materiel Readiness Command
ATTN: DRSAR-MAS
Rock Island, IL 61299

RECOMMENDED CHANGES TO EQUIPMENT TECHNICAL PUBLICATIONS



SOMETHING WRONG WITH THIS PUBLICATION?

THEN... JOT DOWN THE DOPE ABOUT IT ON THIS FORM. CAREFULLY TEAR IT OUT. FOLD IT AND DROP IT IN THE MAIL!

FROM: (PRINT YOUR UNIT'S COMPLETE ADDRESS)

DATE SENT

PUBLICATION NUMBER

TM 9-4910-700-14&P

PUBLICATION DATE

19 June 1981

PUBLICATION TITLE

Test Set, Tachometer, Dwell

BE EXACT... PIN-POINT WHERE IT IS

PAGE NO.	PARA-GRAPH	FIGURE NO.	TABLE NO.

IN THIS SPACE TELL WHAT IS WRONG AND WHAT SHOULD BE DONE ABOUT IT:

TEAR ALONG PERFORATED LINE

PRINTED NAME, GRADE OR TITLE, AND TELEPHONE NUMBER

SIGN HERE:

FILL IN YOUR
UNIT'S ADDRESS

FOLD BACK

DEPARTMENT OF THE ARMY

OFFICIAL BUSINESS
PENALTY FOR PRIVATE USE \$300

POSTAGE AND FEES PAID
DEPARTMENT OF THE ARMY
DOD 314



TEAR ALONG PERFORATED LINE

Commander
US Army Armament Materiel Readiness Command
ATTN: DRSAR-MAS
Rock Island, IL 61299

RECOMMENDED CHANGES TO EQUIPMENT TECHNICAL PUBLICATIONS



THEN... JOT DOWN THE
DOPE ABOUT IT ON THIS
FORM, CAREFULLY TEAR IT
OUT, FOLD IT AND DROP IT
IN THE MAIL.

SOMETHING WRONG WITH THIS PUBLICATION?

FROM: (PRINT YOUR UNIT'S COMPLETE ADDRESS)

DATE SENT

PUBLICATION NUMBER

TM 9-4910-700-14&P

PUBLICATION DATE

19 June 1981

PUBLICATION TITLE

Test Set, Tachometer, Dwell

BE EXACT... PIN-POINT WHERE IT IS

PAGE
NO.

PARA-
GRAPH

FIGURE
NO.

TABLE
NO.

IN THIS SPACE TELL WHAT IS WRONG
AND WHAT SHOULD BE DONE ABOUT IT:

PRINTED NAME, GRADE OR TITLE, AND TELEPHONE NUMBER

SIGN HERE:

DA FORM 2028-2
1 JUL 79

PREVIOUS EDITIONS
& ARE OBSOLETE.

P.S.-IF YOUR OUTFIT WANTS TO KNOW ABOUT YOUR
RECOMMENDATION MAKE A CARBON COPY OF THIS
AND GIVE IT TO YOUR HEADQUARTERS.

TEAR ALONG PERFORATED LINE

FILL IN YOUR
UNIT'S ADDRESS

FOLD BACK

TEAR ALONG PERFORATED LINE

DEPARTMENT OF THE ARMY

POSTAGE AND FEES PAID
DEPARTMENT OF THE ARMY
DOD 314



OFFICIAL BUSINESS
PENALTY FOR PRIVATE USE \$300

Commander
US Army Armament Materiel Readiness Command
ATTN: DRSAR-MAS
Rock Island, IL 61299

RECOMMENDED CHANGES TO EQUIPMENT TECHNICAL PUBLICATIONS



THEN... JOT DOWN THE DOPE ABOUT IT ON THIS FORM. CAREFULLY TEAR IT OUT. FOLD IT AND DROP IT IN THE MAIL!

SOMETHING WRONG WITH THIS PUBLICATION?

FROM: (PRINT YOUR UNIT'S COMPLETE ADDRESS)

DATE SENT

PUBLICATION NUMBER

TM 9-4910-700-14&P

PUBLICATION DATE

19 June 1981

PUBLICATION TITLE

Test Set, Tachometer, Dwell

BE EXACT... PIN-POINT WHERE IT IS

PAGE NO.	PARA-GRAPH	FIGURE NO.	TABLE NO.

IN THIS SPACE TELL WHAT IS WRONG AND WHAT SHOULD BE DONE ABOUT IT:

TEAR ALONG PERFORATED LINE

PRINTED NAME, GRADE OR TITLE, AND TELEPHONE NUMBER

SIGN HERE:

DA FORM 2028-2
1 JUL 79

PREVIOUS EDITIONS ARE OBSOLETE.

P.S.—IF YOUR OUTFIT WANTS TO KNOW ABOUT YOUR RECOMMENDATION MAKE A CARBON COPY OF THIS AND GIVE IT TO YOUR HEADQUARTERS.

FILL IN YOUR
UNIT'S ADDRESS

FOLD BACK

DEPARTMENT OF THE ARMY

POSTAGE AND FEES PAID
DEPARTMENT OF THE ARMY
DOD 314



OFFICIAL BUSINESS
PENALTY FOR PRIVATE USE \$300

TEAR ALONG PERFORATED LINE

Commander
US Army Armament Materiel Readiness Command
ATTN: DRSAR-MAS
Rock Island, IL 61299

TM 9-4910-700-14&P

TEST SET, TACHOMETER, DWELL — 1981